

Systems are available as standard with up to 4 or 6 outlets in either mild steel or stainless steel. Mild steel reservoirs are full polyester powder coated RAL5002, other RAL specs are available on special order. Systems with more than 6 pumps are available to special order.

The reservoirs have fixed lids with filler breathers, the pumps are enclosed within a front cover, which may be removed for adjustment.

All units are fitted with an external sight level and have a drain point. The individual pumps are manifold mounted, with standard manifolds for 4 or 6 pumps. Where less than 4 or 6 pumps are required, blanking plugs seal off the feed point.

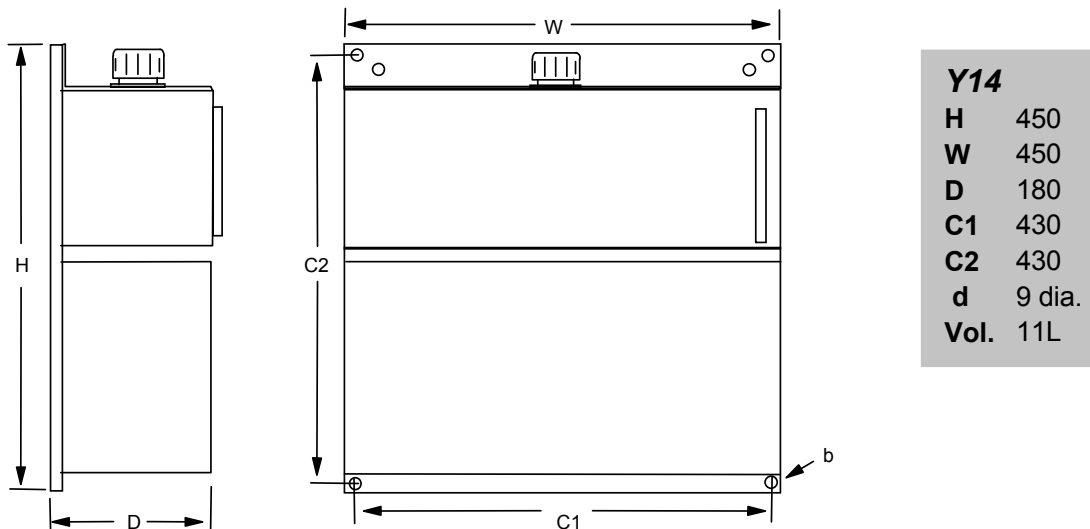

Mounting the system is simple with corner fixing points on the back plate. Connections to the unit are all from below as per the diagram.

Adjustment of the output is simply made using the adjusting nut on each pump unit.

On nozzles with air assist, a manifold unit is fitted with needle valve control of flow.

Each pump/nozzle is independently adjustable. See chart on leaflet Y14/2 for pump volumes.

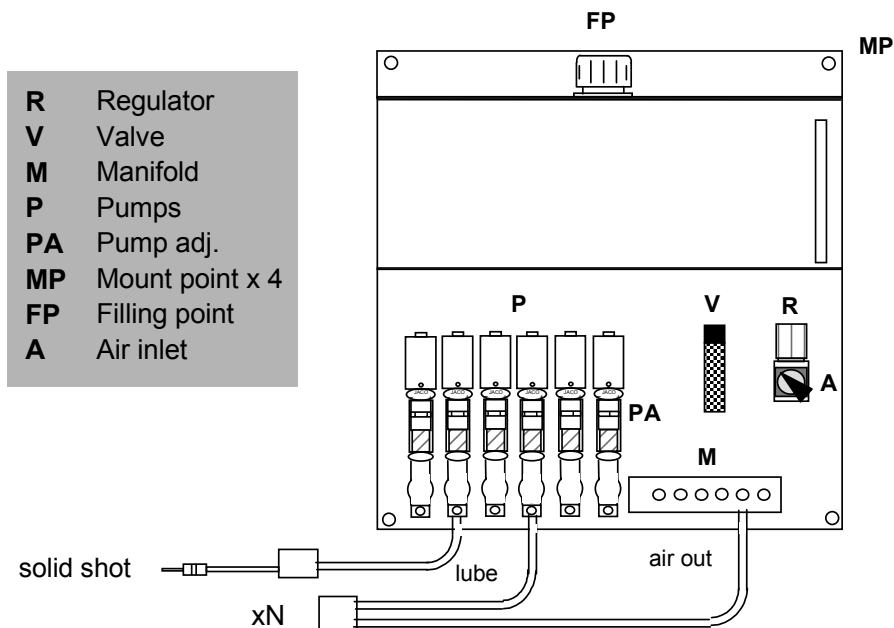

Each **METERLUB** system may be customised with optional equipment and additional features to suit individual customers requirements.

The chart below sets out the standard options from number of pump outlets , types of pump and nozzle to control methods and indication.

At the head of each column is the order prefix which should be quoted when ordering.

Example **Y14 / 2 / B / FS / Sol 24= / MA** is a unit with the following features:

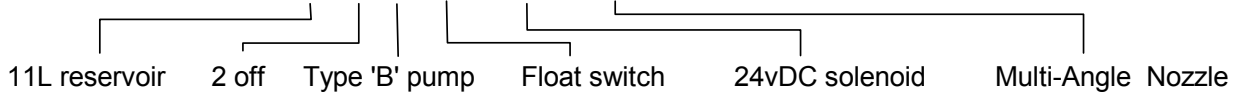

Y14	11 Litre reservoir with pump enclosure pilot operated valve maximum 6 pumps
1 - 6	number of pump units required up to 6 on Y14 Standard system
A B C	Type of pump required on unit (See pump chart below)
FS	Low level float switch volt free contacts
SS	Reservoir in stainless steel
Sol x	Solenoid controlled valve (specify voltage required e.g. 24vDC)
AG	Air agitation of lubricant (where settling of media is expected)
CP	Compression type fittings on lube and air outlets and nozzles
xN	Nozzle type (see selection chart below)

There are 4 standard types of **MINIPUMP** that may be fitted to the system. Each allows for accurate and repeatable application of lubricant to your work piece. Different pressure uplifts and volumes are available to suit your application needs and Lube type. Discuss with your sales advisor which pump type is most suitable for you.

Type 'A' this type projects the set amount of lubricant without spray air and is normally used for small accurate amounts required in very precise areas. A shot velocity adjustment is incorporated into the actuating cylinder on this type of pump.

Type 'B' Where a higher degree of spread is required together with small amounts, e.g. fine presswork. This unit provides the facility to mix air with the lube shot. Both air and lubricant have fine output controls.

Two cylinder sizes giving high and low uplifts are available. See chart below.

Type 'C' This is a larger version of the Type 'B' giving greater volume at reduced force.

Pump options	output	uplift	cyc/min	typ/accy.
Type 'A'	0.3ml/cc	24:1	100	+/- 0.01ml
Type 'B' STD	0.3ml/cc	12:1	120	+/- 0.01ml
Type 'B' MR	0.3ml/cc	24:1	100	+/- 0.01ml
Type 'C' MR	1.2ml/cc	6:1	80	+/- 0.04ml

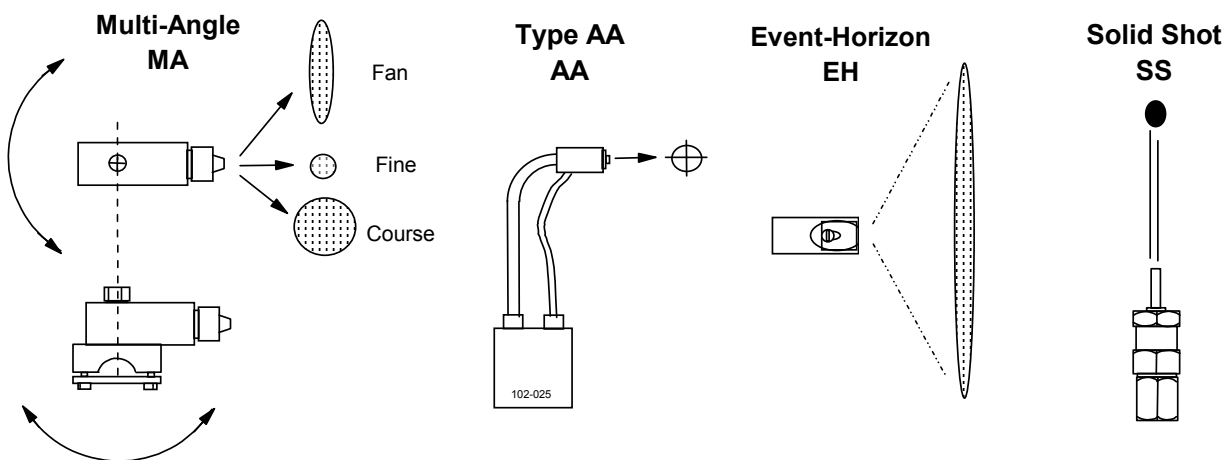

Nozzle Type	Part number	Typical use
Multi-Angle	102-027 MA	general use - presswork - forming or saw application
'AA' Nozzle	102-029AA	fine pressing - cage bearings - conveyor - tapping - drilling
Event-horizon	EH	Wide strip coverage, bandsaw and cutting/forming
Solid-shot	102-037	conveyor bearings - tapping - swaging